

ELECTRIC CONVECTION OVEN WITH HUMIDIFICATION

A single-phase oven 1/1 GN suitable for medium size locals. It allows to obtain simple and delicious foods and the heating of ready meals with the least expenditure of energy. The oven has a degree of IPX3 water protection.

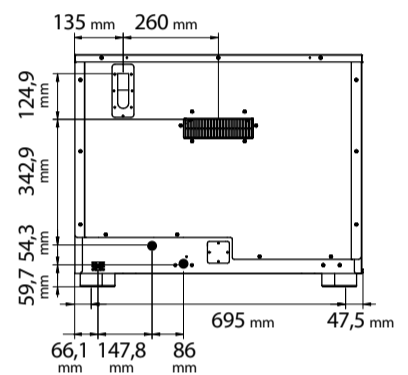
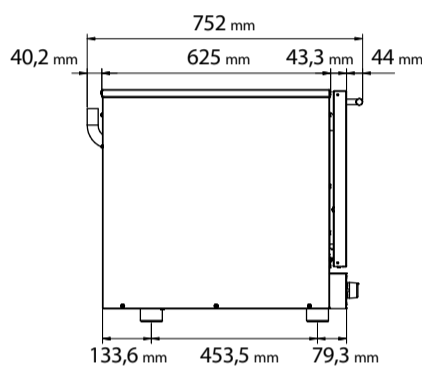
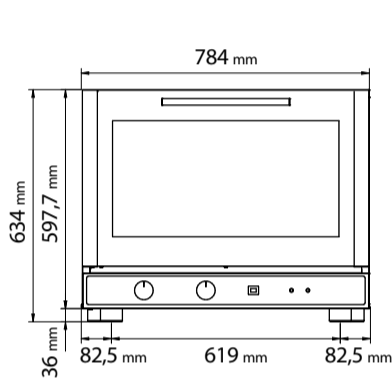

DIMENSIONAL FEATURES			
Oven dimensions (WxDxH mm)	784	752	634
Oven weight (kg)	50,4		
Distance between rack rails (mm)	73		

ELECTRICAL FEATURES	
Power supply (kW)	3,4
Frequency (Hz)	50/60
Voltage (Volt)	AC 220/230
N° of motors	2 Unidirectional
Boiler	/
Protection against water	IPX3

EQUIPMENT			
Cardboard box dimensions with pallet (WxDxH mm)	805	830	800
Lateral supports	1 right + 1 left		
Cable	Single-phase [3G 1,5] - l=1350 mm		

PLUS	
Stainless steel cooking chamber	
Door with inspectionable glass	
Quick fastening of lateral supports	
Embedded gasket	
Stackable	
Forced cooling system of inner parts	
IPX 3	
New design of cooking chamber	
CB certification	
New design of handle	

FUNCTIONAL FEATURES	
Power	Electricity
Capacity	N° 4 trays/grids 1/1 GN
Type of cooking	Ventilated
Humidification	Indirect with button
Cooking chamber	AISI 430 Stainless steel
Temperature	50 ÷ 300°C
Temperature control	Thermostat
Control panel	Electromechanic - Lower side
N° of programs	/
Programmable cooking steps	/
Pre-heating temperature	/
Pre-heating function	/
Door	Tilt door Ventilated Inspectionable glass

OPTIONAL	
Kit for overlapping ovens	Cod. EKKM4
Chromed grid 1/1 GN	Cod. KG9G
AISI 304 vertical chicken cooking pan	Cod. KGP
Fat drip pan for chicken grids	Cod. EKT11RG
AISI 304 tray 1/1 GN (530x325x40mm)	Cod. KT9G
Table	Cod. EKT 411 - Cod. EKTR 411 Cod. EKTS 411 - Cod. EKTRS 411 Cod. EKT 411 D

