

# EKF 423 P

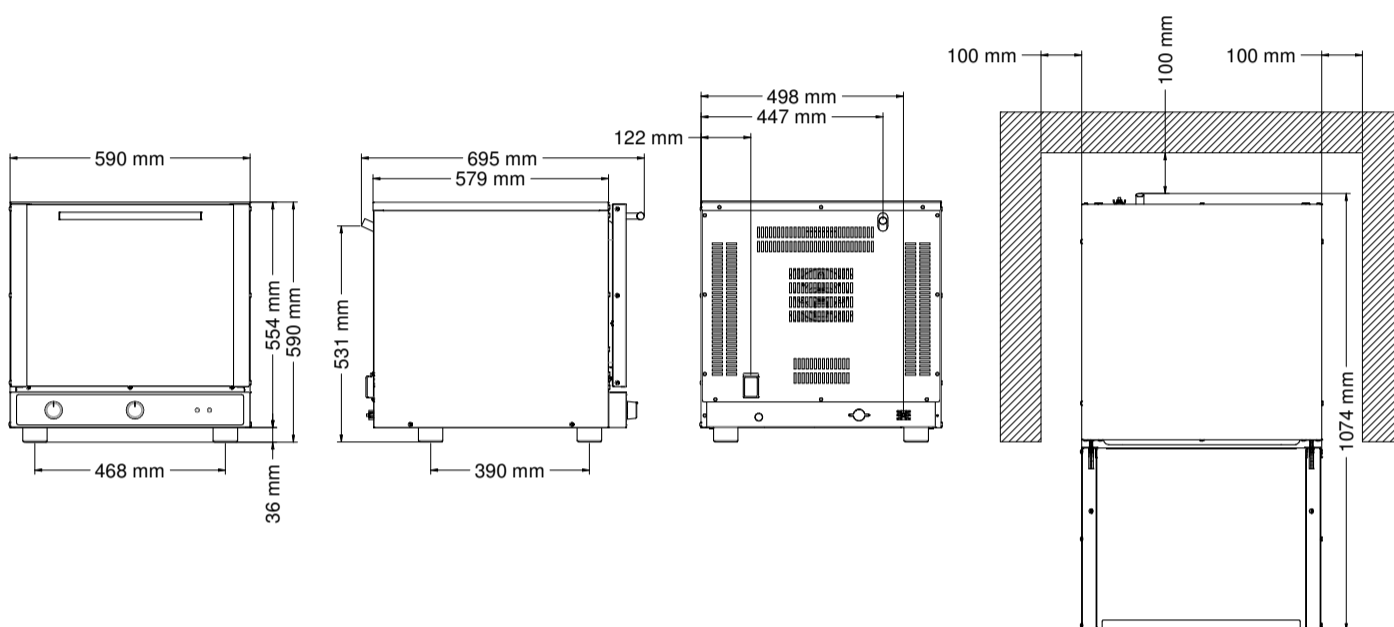

## ELECTRIC CONVECTION OVEN

Easy to use and set thanks to the analogic control panel. You can serve flavorful and tasty snacks that will satisfy the desires of your customers.



### DIMENSIONAL FEATURES

Oven dimensions (WxDxH mm)	590	695	590
Oven weight (kg)	33		
Distance between rack rails (mm)	74		

### ELECTRICAL FEATURES

Power supply (kW)	2,8
Frequency (Hz)	50/60
Voltage (Volt)	AC 220/230
N° of motors	1 Unidirectional
Boiler	/
Protection against water	/

### EQUIPMENT

Cardboard box dimensions (WxDxH mm)	650	760	600
Lateral supports	1 right + 1 left		
Aluminium tray (429x345 mm) Cod. KV7	4 Pcs		
Cable	Single-Phase [3G 1,5] - L=1600 mm		

### OPTIONAL

Available in the dedicated section
------------------------------------

### FUNCTIONAL FEATURES

Power	Electricity
Capacity	N° 4 Trays (429x345 mm)
Type of cooking	Ventilated
Humidification	/
Cooking chamber	AISI 430 Stainless Steel
Temperature	100 ÷ 260°C
Temperature control	Thermostat
Control panel	Electromechanic - Lower side
N° of programs	/
Programmable cooking steps	/
Pre-heating temperature	/
Pre-heating function	/
Door	Tilt door Ventilated Inspectionable glass
Modularity	Available

### PLUS

Door with inspectionable glass
Stainless steel cooking chamber
Embedded gasket
New design of cooking chamber