

EKF 423 UD



ELECTRIC CONVECTION OVEN WITH STEAM



Designed for small bakeries and pastry businesses wanting a compact, practical and efficient appliance. The direct steam option means it caters to a whole host of cooking requirements: it is the ideal solution for baking fragrant plain or filled croissants, as well as for rethermalizing frozen bread, with excellent results guaranteed.

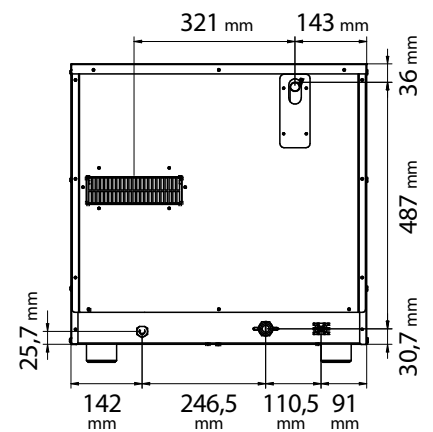
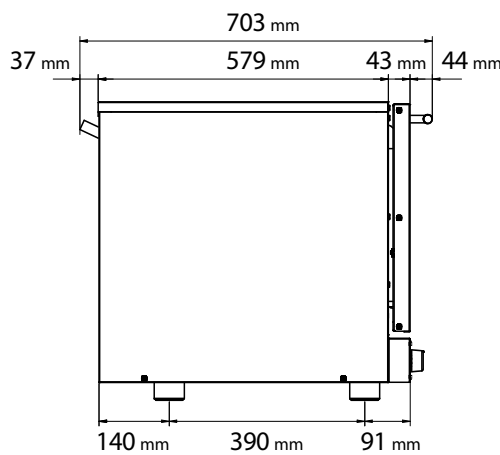
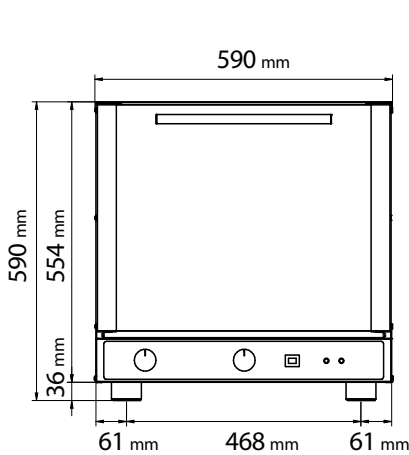

DIMENSIONAL FEATURES			
Oven dimensions (WxDxH mm)	590	703	590
Oven weight (kg)	38		
Distance between rack rails (mm)	74		

ELECTRICAL FEATURES	
Power supply (kW)	2,9
Frequency (Hz)	50 (60 on demand)
Voltage (Volt)	AC 220/230
N° of motors	1 Bidirectional
Boiler	/
Protection against water	IPX3

EQUIPMENT			
Cardboard box dimensions (WxDxH mm)	650	760	600
Lateral supports	1 right + 1 left		
Aluminum trays (429x345 mm)	4 pcs		
Cable	Single-phase [3G 1,5] - l=1600 mm		

PLUS	
Stainless steel cooking chamber	
Door with inspectionable glass	
Embedded gasket	
Stackable	
Forced cooling system of inner parts	
IPX 3	
New design of cooking chamber	
CB certification	
New design of handle	

FUNCTIONAL FEATURES	
Power	Electricity
Capacity	N° 4 Trays (429x345 mm)
Type of cooking	Ventilated
Steam	Direct automatic
Cooking chamber	AISI 304 Stainless steel
Temperature	50 ÷ 300°C
Temperature control	Thermostat
Control panel	Electromechanic – Lower side
N° of programs	/
Programmable cooking steps	/
Pre-heating temperature	/
Pre-heating function	/
Door	Tilt door Ventilated Inspectionable glass

OPTIONAL	
Aluminium tray (429x345x9,20 mm)	Cod. KV7
AISI 430 adapter kit 2/3 GN (354x325 mm)	Cod. KPG23
Horizontal chromed grid (435x340 mm)	Cod. KG7
AISI 304 horizontal grid (435x340 mm)	Cod. KG7X
Perforated aluminium tray (435x345x10 mm)	Cod. KTF6P
Kit for overlapping ovens	Cod. EKKM 423
Table	Cod. EKT 423 - Cod. EKTR 423 Cod. EKTS 423 - Cod. EKTRS 423 Cod. EKT 423 D
Proofer	Cod. EKL 823
Water tank lt. 7	Cod. EKSA
Pump kit with hose and filter	Cod. KKPU
Air reducer	Cod. EKRPA/A
Optional packaging	Cod. 01300731 Cage Cod. 01300900 Pallet HT treated (800x1200x118mm)

