

ETE7

Combi Electric Oven - 7 GN 1/1_ 7GN 60x40



TECHNICAL FEATURES

- Heating of cooking chamber with high performance INCOLOY heating elements.
- Adjustable fan speed in 3 position.
- Double-glazed ventilated door (panels can be opened for easy cleaning).
- AISI 304 cooking chamber with rounded corners.
- Height adjustable feet.
- USB port for uploading and saving recipes and for firmware updating.
- Motorised vent valve opening
- Single control by means of just one jog/dial encoder knob.

OPTIONS:

- ETE7W Washing system included
- Optional rack for 60x40 trays.

USER INTERFACE:

TOUCH SCREEN PANEL 5"

Convection, steam, convection with steam in combi mode, humidification and dehumidification, cook with core probe, hold in temperature for overnight cooking.

These are the Easyair's functions, an oven line which is suitable to take either gastronomic and confectionery size trays and containers.

RecipeTuner

The RecipeTuner interface makes it possible to modify and personalise the various programs simply and intuitively. RecipeTuner changes according to the type of cooking set, to regulate cooking, browning, degree of humidity and of leavening.

EasyService

level control cooking

The new Rack Control enables different dishes to be cooked at the same time at various levels. What's more, with EasyService, a new Rack Control function, all the dishes can be served at the same time.

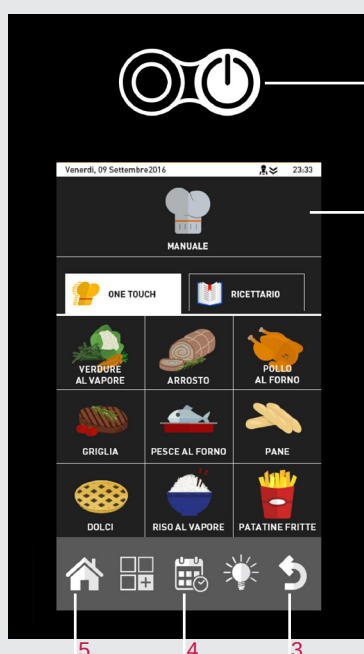

1. On/Off switch.
2. Touch Screen Panel.
 - Temperature control from 50° to 300°C
 - Time control from 1' to 120'; infinite function.
 - Cooking modes: convection, steam, combi convection/steam.
 - "One Touch" cooking mode: immediate start of the cooking cycle with "one touch programs".
 - Preset cooking programmes. Possibility of controlling 9 cooking phases for each programme.
 - Cooking with "Rack Control"
 - Interface "Recipe Tuner"
 - Delta T cooking.
 - Cooking with probe.
 - Multi level cooking with "Easy service"
 - Fan with 3 different speeds.
 - Motorised vent valve opening .
3. Back Key
4. "Scheduled Departure" key.
5. Main Menu key.

ETE7

Combi Electric Oven - 7 GN 1/1_ 7GN 60x40

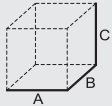
 (A x B x C) mm	VOL./PESO Vol./Weight m ³ /kg	VAC 400V-3N 50Hz (60 Hz optional) kW	POTENZA EL. CAMERA Oven cavity el. power kW	DISTANZA TRA LE TEGLIE Distance between the layers mm	DIM. CAMERA Cavity net dimension mm
870x749x823 7 GN 1/1 7 EN 60x40	0,8 / 105	9,6	9	74	645x600x450

ACCESSORIES

- Stand TSP1000
- Racks for stand TSP1000 cod. 2017692
- Proofer CLP0810
- Proofer CL900
- Proofer CL912
- Hood 7080516
- Condensation hood 7080522
- Core probe 6000116
- Probe for sous-vide cooking 6000117
- Hand spray 7080003
- Stacking kit on demand

ACCESSORIES FOR PATISSERIE USE

- 2023824 racks 60x40 size 80.
- 2021519 racks 60x40 size 100

- A Electrical connection
- B Water inlet (G3/4)
- C Drain connection (Ø32)

WATER QUALITY REQUIREMENTS

Hardness 60-100 ppm
TDS <100 mg/L
PH Value 7.0-8.0
Cl₂ Free chlorine..... <0,5 mg/L
Cl Chloride..... <20 mg/L
Alkalinity..... <20 mg/L
SiO₂ Silica..... <10 mg/L

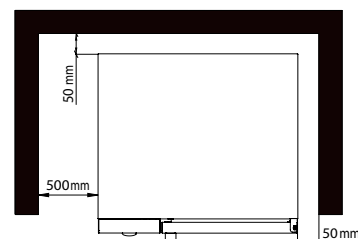
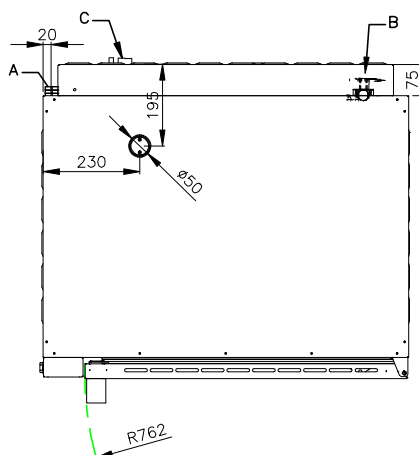
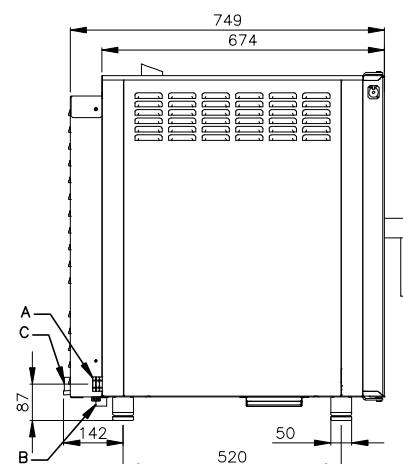
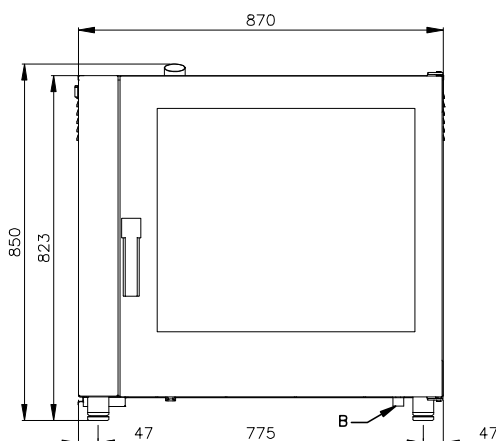

* Clearance requirements

NOTE

* Drain line must be vented